

# Notice de Montage

## MTR - MEA

**GB** *Assembly instructions MTR - MEA*

**D** *Montageanleitung MTR - MEA*

**I** *Istruzioni di montaggio MTR - MEA*

**E** *Manual del operador MTR - MEA*

**ALDES**

[www.aldes.com](http://www.aldes.com)



## INSTALLATION : TRAVERSEE DE MUR RECTANGULAIRE

**GB** Installation: ??

**I** Installazione: ??

**D** Installation: ??

**E** Instalacion: ??

1

Traversée de mur rectangulaire :  
droit femelle à sceller

**GB** ??

??

**D** ??

??

**I** ??

??

**E** ??

??

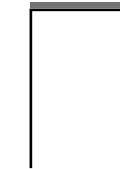
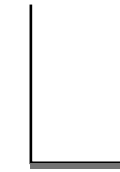

2



Taille réservation Droit femelle

**GB** ??

**D** ??

**I** ??

**E** ??

3

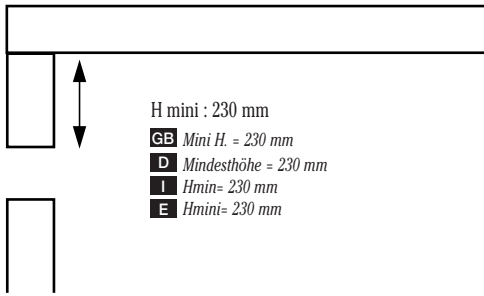

H mini : 230 mm

**GB** Mini H. = 230 mm

**D** Mindesthöhe = 230 mm

**I** Hmin= 230 mm

**E** Hmini= 230 mm

Positionnement réservation

**GB** Positioning of the reserve opening

**D** Position der Aussparung

**I** Posizionamento della riserva

**E** Posicionamiento de la reserva



# INSTALLATION MTR

**GB** *Installation MTR*    **D** *Installation MTR*  
**I** *Installazione MTR*    **E** *Instalación MTR*

1

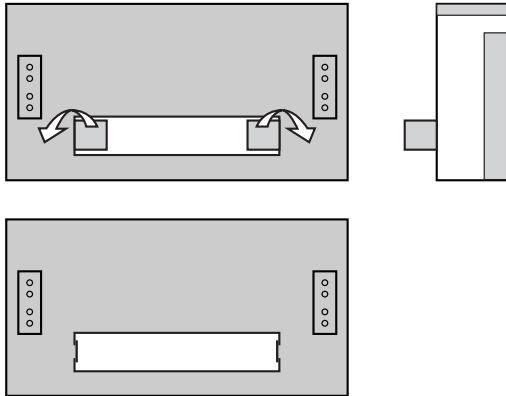

2

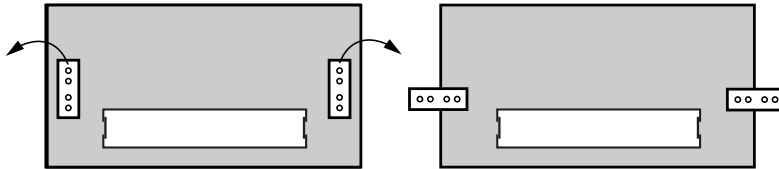

3

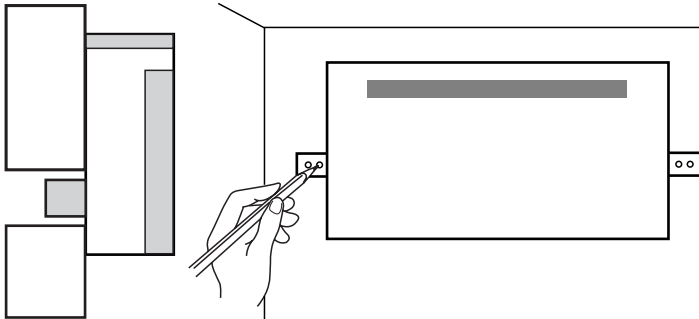

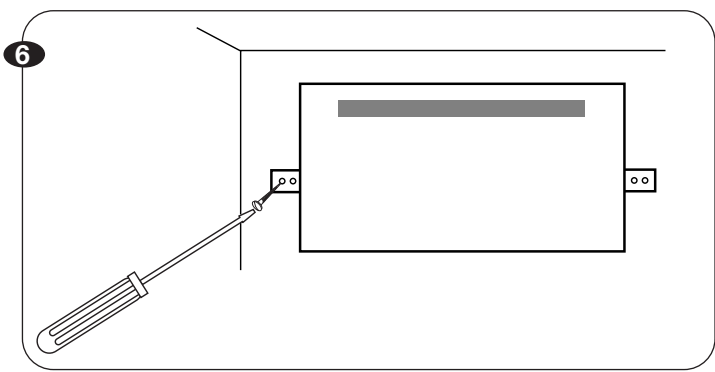
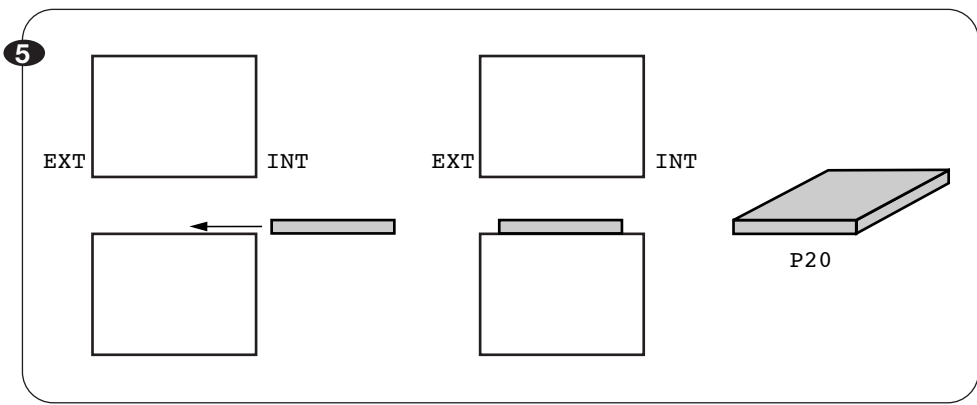
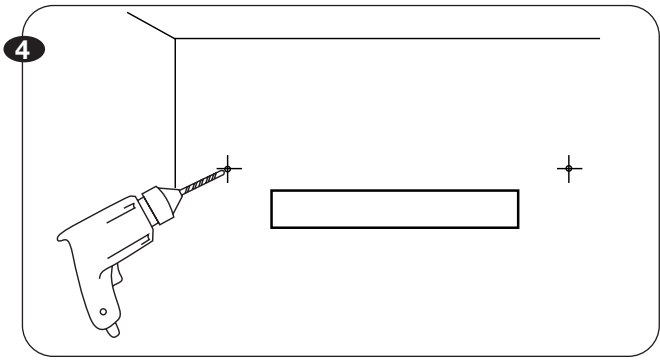



## INSTALLATION DE L'ISOLANT : Isolant + BA 13 séparés

**GB** Installation of the insulation: Insulator + BA13 separately

**D** Anbringung der Isolierung: Isolierung + BA13 getrennt

**I** Installazione dell'isolante: isolante + pannelli BA13 separati

**E** Instalacion del aislante: Aislante + BA13 separados

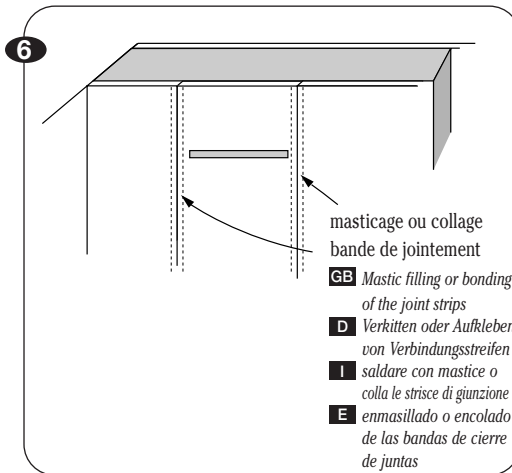
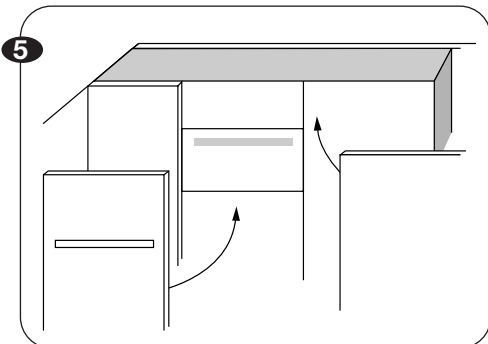
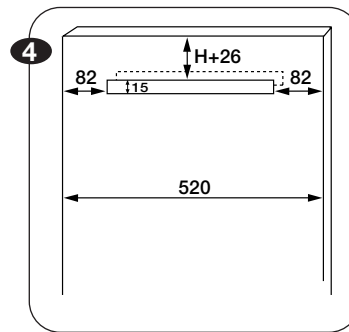
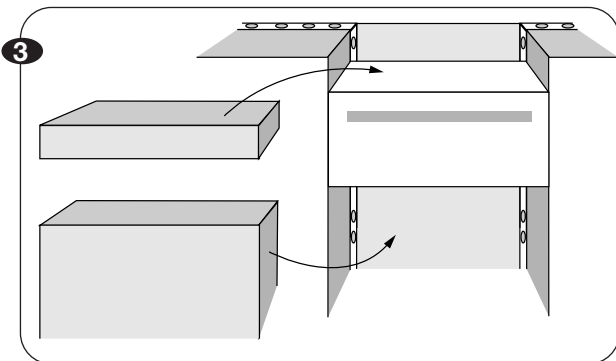
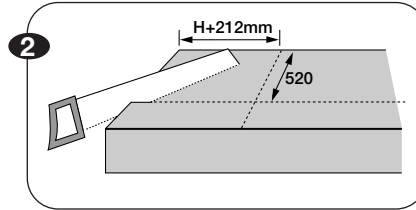
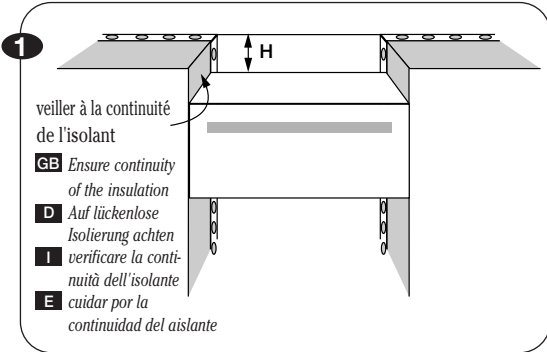



## INSTALLATION DE L'ISOLANT : Complexe monobloc

**GB** Installation of the insulation: Monobloc Assembly

**D** Anbringung der Isolierung: Massiver Verbund

**I** Installazione dell'isolante: Complesso monoblocco

**E** Instalacion del aislante: Complejo monobloque

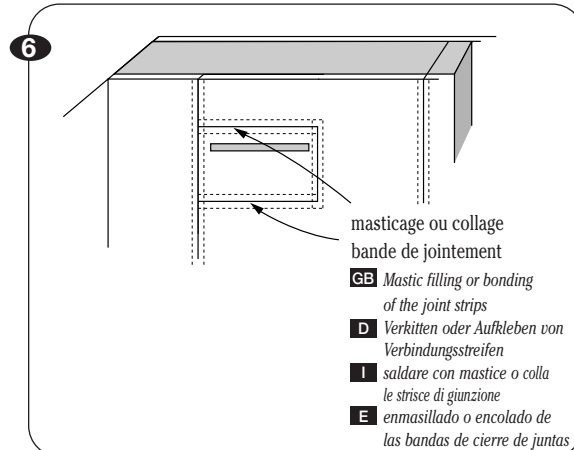
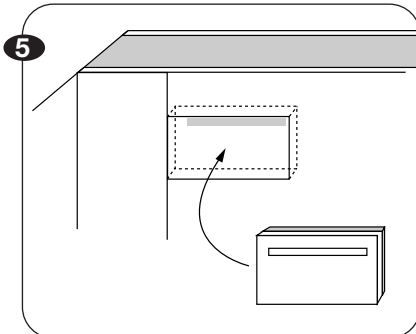
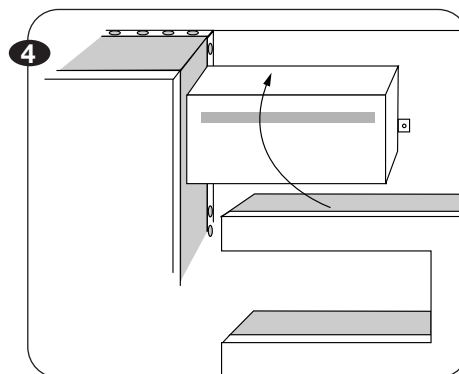
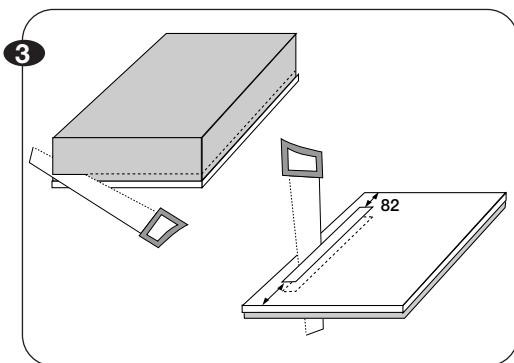
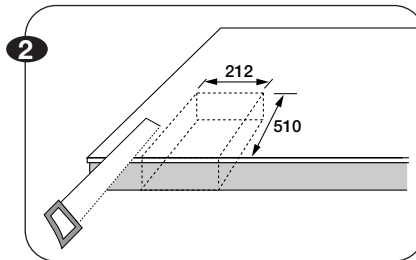
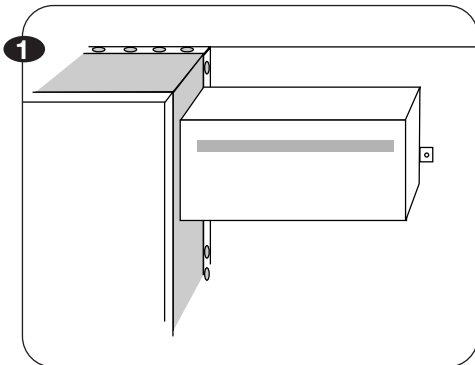

masticage ou collage  
bande de jointement

**GB** Mastic filling or bonding  
of the joint strips

**D** Verkitten oder Aufkleben von  
Verbindungsstreifen

**I** saldare con mastice o colla  
le strisce di giunzione

**E** enmasillado o encolado de  
las bandas de cierre de juntas



## INSTALLATION MEA - ENTRÉE D'AIR - AUVENT EXTÉRIEUR

**GB** Installation MEA - Air inlet - Exterior housing

**D** Installation LEM - Lufteinlass - Windschutz außen

**I** Installazione MEA - Ingresso aria - Controvento esterno

**E** Instalación MEA - Entrada de aire - Saledizo exterior

1

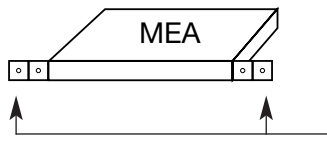

pattes de fixation EHA à casser pour fixations  
EHB / Emma / EA / ELLIA

**GB** EHA fixing lugs: to be broken off  
for EHB/EMMA/EA/ELLIA fixings

**D** Befestigungslaschen EHA: bei der Befestigung  
EHB/EMMA/EA/ELLIA abbrechen

**I** Asole di fissaggio EHA: da rompere per fissare  
EHB/EMMA/EA/ELLIA

**E** Patas de fijación EHA: a romper para fijación  
EHB/EMMA/EA/ELLIA

2

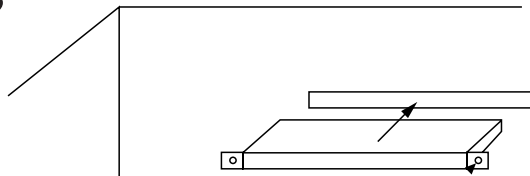

Glisser le MEA dans la fente

**GB** Slide the MEA into the slot

**D** LEM in den Schlitz schieben

**I** Infilare il MEA nella fessura

**E** Deslizar el MEA en la ranura

3

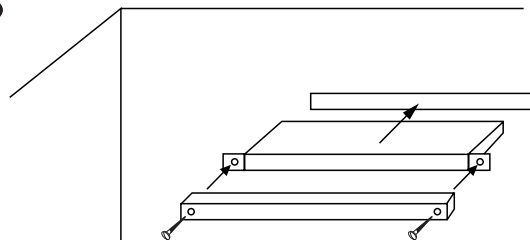

Visser le socle de l'entrée d'air

**GB** Screw in the air inlet's base

**D** Sockel des Lufteinlasses festschrauben

**I** Avvitare il supporto dell'ingresso d'aria

**E** Atornillar el zócalo de entrada de aire

4

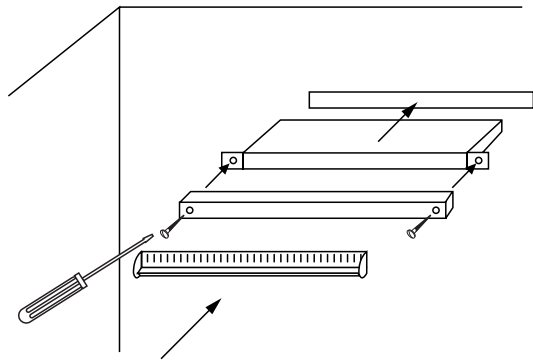

**Clipper le capot**

- GB** *Clip on the hood*
- D** *Abdeckung aufklippen*
- I** *Agganciare il carter*
- E** *Presillar el capón*

5

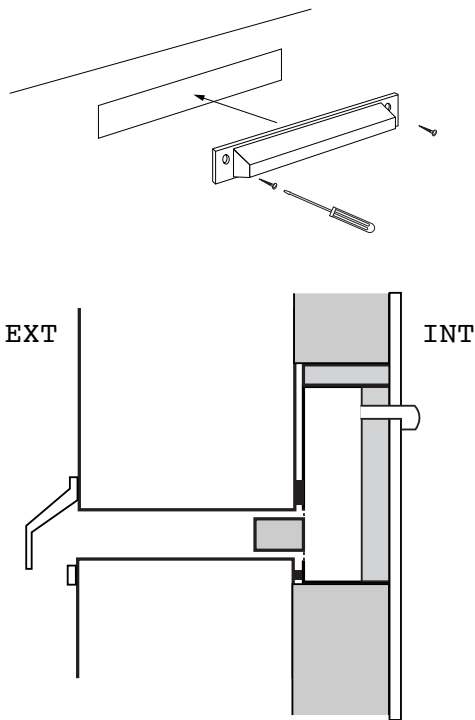

**Installer l'auvent extérieur**

- GB** *Install the exterior housing*
- D** *Windschutz außen anbringen*
- I** *Installare il controvento esterno*
- E** *Instalar el saledizo exterior*